

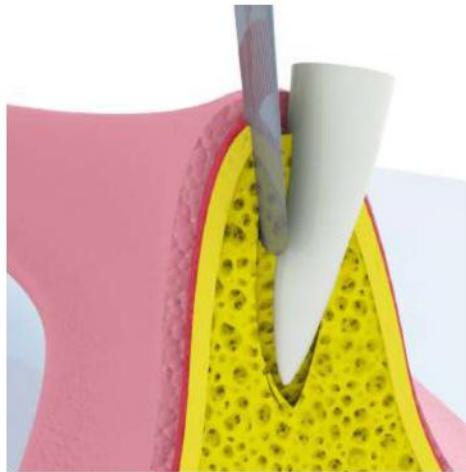

# TOOTH EXTRACTION



**Fig 1.** The magnetic Mallet blade gently detaches the root from the alveolus

The extraction kit offers a set of 5 blades both straight and curved for better access to the posterior regions, for a total of 10 instruments.

### EXTRACTOR

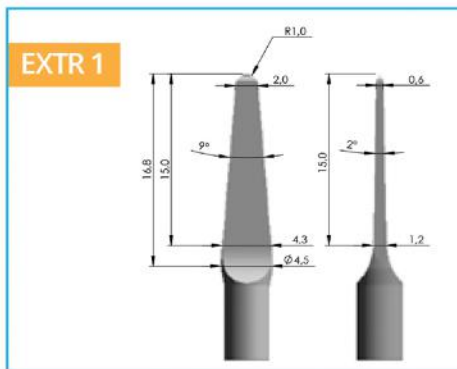

### EXTRACTOR SHORT BLADE

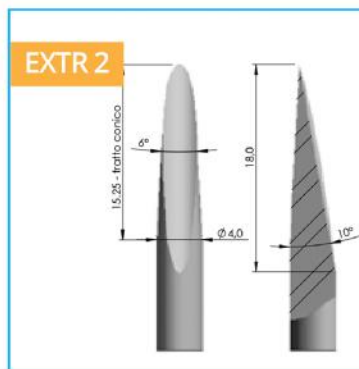

### EXTRACTOR LONG BLADE

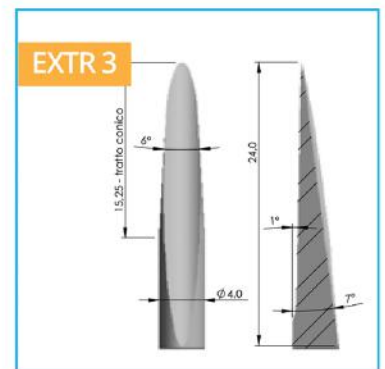

### EXTRACTOR FOR WISDOM TEETH SHORT

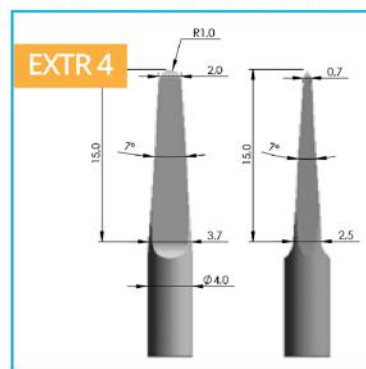

### EXTRACTOR FOR WISDOM TEETH LONG

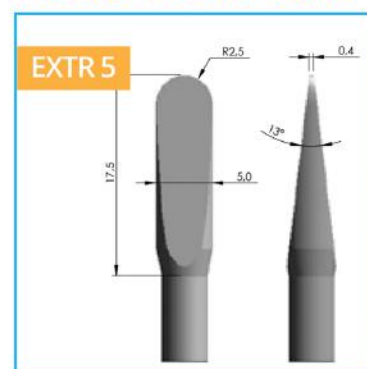

## Surgical Protocol

The Magnetic Mallet for extraction procedures is to be set at force 3 or 4 for standard handpiece and force 2 or 3 for plus handpiece.

The Magnetic Mallet imparts a fast longitudinal movement to the blade which moves up and down on a constant 1.1mm run between the root surface and the lamina dura of the alveolus. The volume of the blade slightly compresses the bone and progressively detaches the root. As the blade progresses into the alveolus, the root is mobilized and pushed out.

**In Monoradicular teeth**, the blade is inserted in mesial palatal and distal side of the tooth. Keeping the blade parallel on the long axis of the root, the blade should follow the contour of the tooth progressing apically.

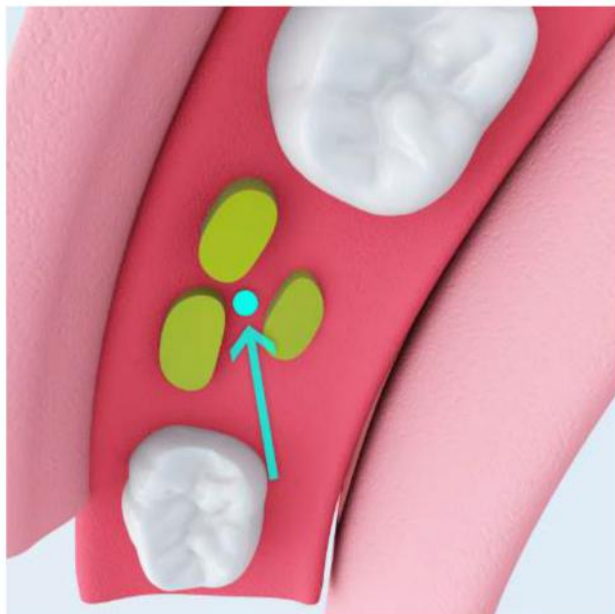

**Fig 3.** The blade is inserted mesial and distal



**Fig 4.** Extractor 1

**Multirrooted teeth** may require surgical sectioning (using a drill or a micro-saw) to convert the tooth into multiple monoradicular teeth and proceeding with the same protocol above mentioned.



**Fig 6.**



**Fig 7.**

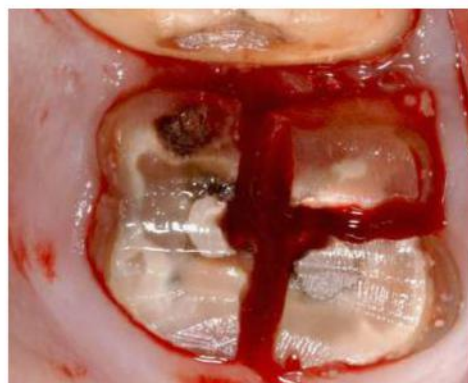

**Fig 8.**

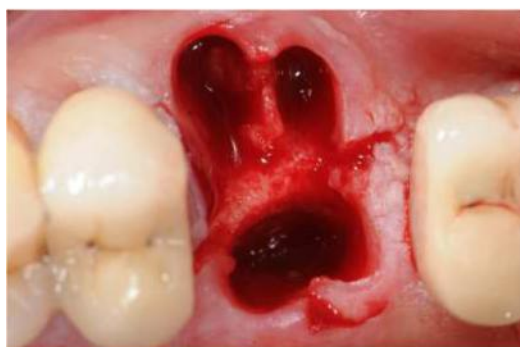

**Fig 9.**

# FRESH SOCKET IMPLANTS

The flapless procedure, made possible with the Magnetic Mallet system, preserves the dental papillae, optimizing aesthetic outcomes. Fig. 11-14

In monoradicular maxillary teeth, during fresh socket implant procedure it must provide a new implant site with different axes respect alveolus. When alveolar bone is thin, use of osteotome for implant site preparation is mandatory. Magnetic Mallet is set at **force number 4** for standard handpiece (**540 daN**) and **force number 3** for plus handpiece (**560 daN**).

The implant site is created expanding the bone tissue both laterally against the preexisting lateral walls and apically moving up and compressing with hand mallet a progressive series of bone expanders. Bone expansion is carried out with osteotomes directly attached and pushed by electrical mallet. An axial force is applied.

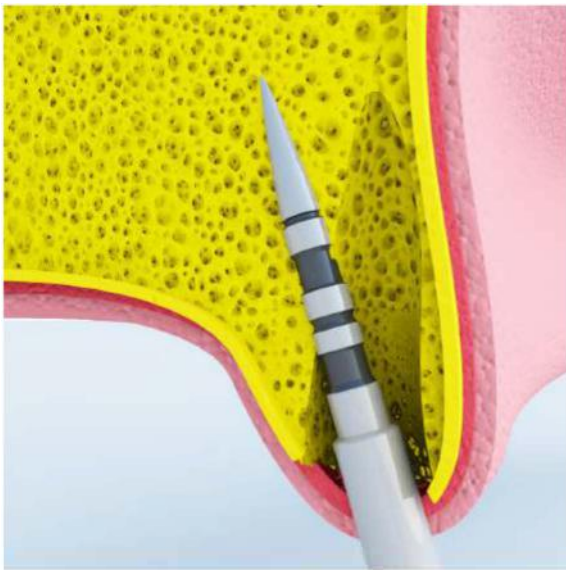

**Fig 21** implant site preparation

Such sequence of engaged surface progressively act upon and force internal wall of initial hole radially outward with respect to central axis to create high density bone tissue along substantial portion of length of bone wall.

In such cases, direct initial preparation is recommended using a D 100 cylindrical osteotome without any initial mechanical drilling. Successively D 200 and D 300 are used for expanding and bone condensing.

Magnetic Mallet is set at **force number 4** for standard handpiece (**540 daN**) and **force number 3** for plus handpiece (**560 daN**).



**Fig 22.** Different osteotomes used for implant site preparation